

ÇUKUROVA



FORKLIFT TRUCKS CF 30PS/40FX

“ Embodiment of Power...”



Characteristics

			CF 30PS	CF 40FX
Load Capacity	kg	Q	3000	4000
Load Center	mm	C	500	500
Power Type			Diesel	Diesel
Operator Position			Seated	Seated
Tyres			P	P
Wheels (x = driven)			2x / 2	2x / 2

Dimensions

			CF 30PS	CF 40FX
Max. Lifting Height	mm	h3	**3200	**3185
Free Lift	mm	h2	*	*
Full Free Lift	mm	h5	*	*
Forks	mm	L1xB2xS	1100x125x45	1100x125x45
Tilt Of Mast	Degrees	a/b	6/10	6/10
Length To Fork Face	mm	L2	2695	2995
Overall Width	mm	B1	1340	1418
Height (lowered mast)	mm	h1	**2295	**2360
Height (extended)	mm	h4	**3879	** 3937
Height (guard)	mm	h6	2150	2265
Turning Radius	mm	Wa	2420	2600
Load Distance	mm	X	575	550
90 Stacking Aisle	mm	Ast4	4105	4450

Performance

			CF 30PS	CF 40FX
Stability	DIN/ISO		Yes	Yes
Travel :With / Without Load	km/h		19/20	17/18
Lift: With / Without Load	m/s		0.40	0,40
Lowering: With / Without Load	m/s		0.45	0.45
Drawbar Pull Max.	N		20000	18900
Gradeability Max.	%		***24	***21

Weight

			CF 30PS	CF 40FX
Unladen Weight	kg		4530	5700
Unladen Front Axle	kg		1970	2280
Unladen Rear Axle	kg		2580	3420
Laden Front Axle	kg		6620	8490
Laden Rear Axle	kg		930	1210

Chassis

			CF 30PS	CF 40FX
Tyres Front			8.5X15-15	8.25x15-14
Tyres Rear			6.5x10-10	7.00x12-14
Wheel Base	mm	Y	1750	1900
Tread Width Front	mm	t1	1108	1184
Tread Width Rear	mm	t2	1016	1090
Under Clearance (mast)	mm	Z	130	135
Under Clearance (cow)	mm	H1	210	220
Service Brake (foot)			Hydraulic	Hydrostatic + Hydraulic
Parking Brake			Mechanical	Mechanical

Engine

			CF 30PS	CF 40FX
Battery Voltage / Capacity	V/ah		12/90	12/105
Engine - Model			HYUNDAI D4BB-C7 AG45	JOHN DEERE 4045TF280
Engine - Emission			STAGE 3A	STAGE 3
Engine output / rpm	Bhp/rpm		53/2500	84X2400
Engine torque / rpm	Nm/rpm		173/1500	302/1700
No Cylinder / Displacement	cm ³		4/2607	4/4500
Cylinder Bore X Stroke	mm		91,1/100	106X127
Fuel Tank Capacity	lt		70	85

Power Train

			CF 30PS	CF 40FX
Transmission			Powershift	Hydrostatic
Clutch			Inching	–
No of Speeds (fwd/rws)			1/1	1/1

Hydraulic

			CF 30PS	CF 40FX
Operating pressure (attch.)	bar		195	195
Steering			Hydrostatic	Hydrostatic
Hydraulic Tank Capacity	lt		50	85

* Optional ** Standard Mast Dimensions *** Calculated Value

- Illustrations and data may differ from standard equipment.
- Specifications are subject to change without notice.
- See your ÇUKUROVA dealer for available options.

FORKLIFT TRUCKS CF 30PS/40FX

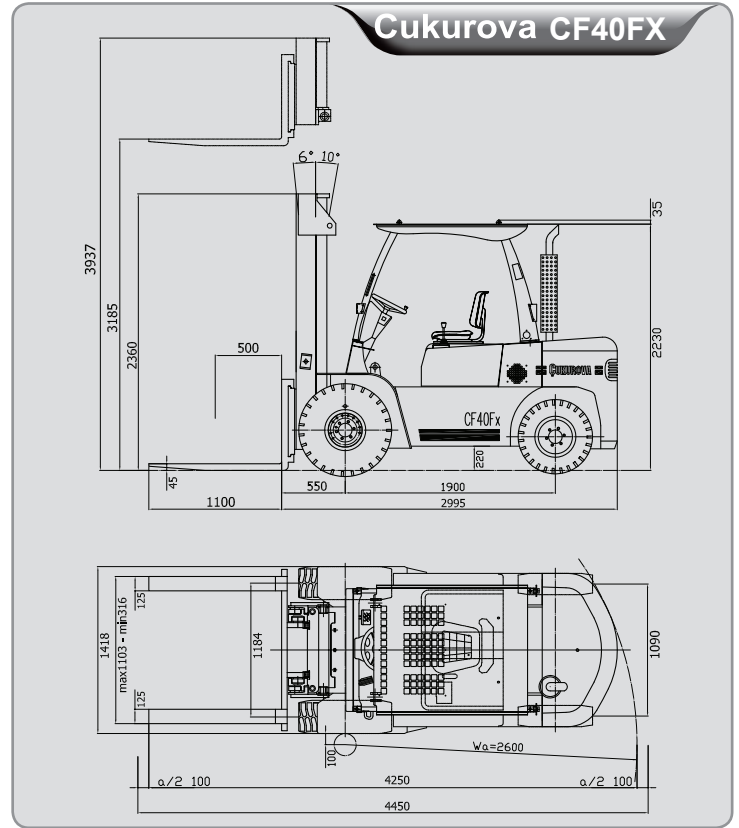
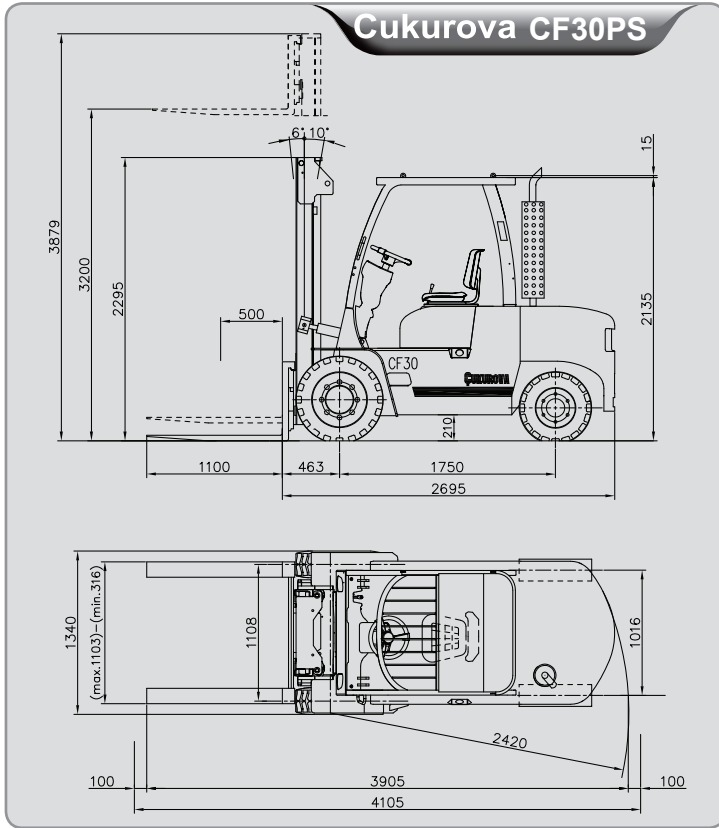

CF30PS	Mast Type	Maximum Fork Height		Mast Height		Full Free Lift	Load Capacity At 500mm Of The Load Center kg
		h3 mm	h1 mm	h4 mm	h5 mm		
			Lowered	Extended			
	DU01	3200	2295	3879	-		3000
	DU02	4000	2695	4679	-		2730
	DU03	4500	2945	5179	-		2560
	DU04	5000	3195	5679	-		2400
	FFL5	2750	2000	3430	1334		3000
	FFT6	4060	2000	4760	1318		2570
	FFT7	4950	2295	5645	1613		2280
	FFT8	6150	2695	6845	2013		1900

CF40FX	Mast Type	Maximum Fork Height		Mast Height		Full Free Lift	Load Capacity At 500mm Of The Load Center kg
		h3 mm	h1 mm	h4 mm	h5 mm		
			Lowered	Extended			
	DU01	3185	2360	3937	-		4000
	DU02	4045	2790	4797	-		3630
	DU03	4550	3040	5297	-		3410
	DU04	5050	3290	5797	-		3200
	FFL5	2930	2150	3685	1412		4000
	FFT6	4285	2150	5064	1391		3270
	FFT7	4920	2360	5694	1601		2990
	FFT8	6210	2790	6984	2031		2430

Lifting Capacities

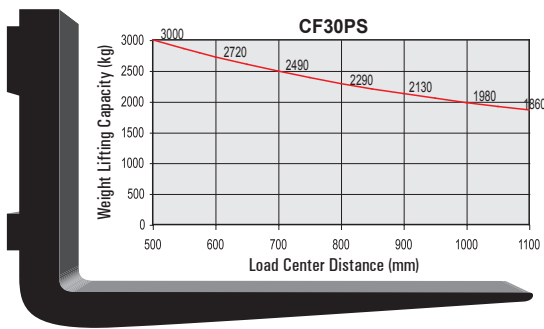

Lifting Capacities

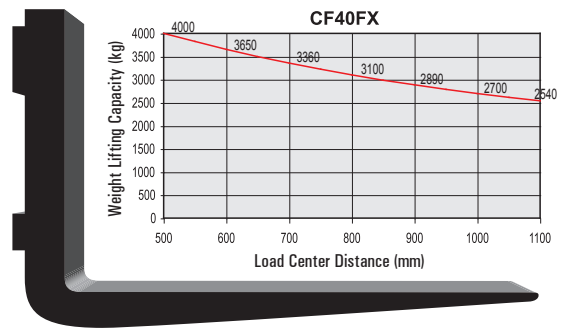

CE marked - All safety measurements are taken through the Machinery Directives 2006/42/EC