



HD65/HD72



Hyundai Motor Company
231 Yangjae-Dong, Seocho-Gu
Seoul, Korea
TEL : 82-2-3464-3192
FAX : 82-2-3464-3513
www.hyundai-motor.com
Printed in Korea. Dec. 2003 / WD



Get Moving Like Never Before

Whether you're coming or going, with or without a payload, you not only need top performance but economy, durability and reliability. Simple to maintain and efficient to operate, the HD65/72 Series deliver in every way.



Discover the Hyundai Advantage

With the new HD65/HD72 trucks, there are more reasons than ever to consider choosing a Hyundai. You get more power, more comfort and more of everything to keep you ahead of the competition. Take a good look at these newest models from Hyundai and see the benefits of choosing Hyundai. It's definitely the smart choice.

HD65/HD72 Super Cab

More Room for More Comfort!



HD65 Narrow Cab

*Maximized drivability
With Slimmed cab and deck!*





xterior & Styling

E X T E R I O R & S T Y L I N G



One look tells you these trucks are special. But beneath the smart styling you'll discover a remarkable attention to engineering details to enhance performance, efficiency and reliability. So you get the most out of your investment

Great Euro-Styling is Just the Beginning



Built-In Washer

The windscreen washer is built into the wipers. This improves washer fluid dispersion and increases the washer coverage area for safer driving



Wide-View Windscreen

Expansive windscreen provides an excellent forward field of view for confident, safe driving.



Extra-Large Bumper

Massive front bumper provides an extra measure of protection.



Styled Head Lamps

Dual styled-type head lamps are stacked and provide excellent illumination.



Large Side Mirrors

Improved side view coverage for safer driving.



Built-In Fog Lamps

Optional feature that enhances driving safety when visibility is poor.



Chromed Radiator Grill

More than a smart styling touch, the large aperture enhances cooling efficiency. (optional except Narrow Cab)



Aluminium Safety Steps

Non-slip surface thanks to the toothed grate-type finish. (Deluxe Model)



Side Character Line

Side Character lines add a sporty, muscular note which defines the HD's dynamic and nimble image.



Recessed Door Handles

New design looks better and is more secure.



No matter which model you choose, you'll enjoy one of the roomiest cabs around. There's more room to relax and get the job done quickly and easily. Check out the numerous comfort and convenience features that come at no extra charge and you'll agree that when it comes to comfort, Hyundai is ahead of the rest.

Comfortable and Cozy Interior Space

There's plenty of room behind the seat to store tools and other essentials on super cab. Super trim seats shown here include semi-cloth upholstery and center seat back console with cupholder.



Greater Comfort for Greater Driver Satisfaction

In designing interior for the HD65 / 72 truck series, our primary design goal was total driver satisfaction. Just slip into the driver's seat and you'll not only see but feel the difference.

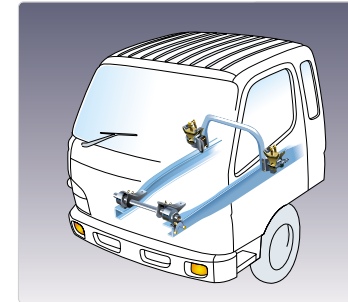

Semi-Floating-Type Cab Suspension

The cab rides on two oil-cushioned rubber mounts. This design innovation is one of the keys to the soft, gentle ride. (Optional for DLX models)

High Back Seats

HD65/72 series trucks are equipped with high back premium seats that include built-in headrests, sliding and reclining adjustments. A coil-type seat suspension is available as an option. Seats are upholstered with high durability materials.

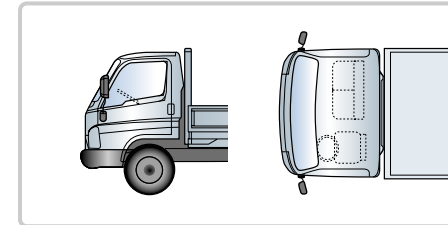
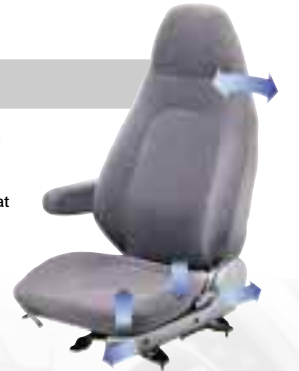

Standard Cab Offers Comfortable Cabin with Durability

The inside cabin of the standard cab is not only built toughly to last but also offers the same amenities and comfort found only in sedans. The ergonomically designed dashboard and a fully supportive seat that hugs the body will satisfy every need in the enduring ride.

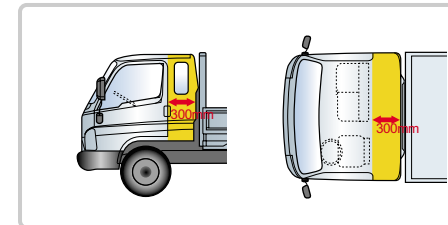

The Longer Super Cab Offers Space and Comfort of a Sedan

The extra 300mm cab length, the first of its kind in the medium size truck class, means more space and utility. This new revolutionary super cab is comfortable and spacious for extra storage and for that much needed rest in a long road trip.

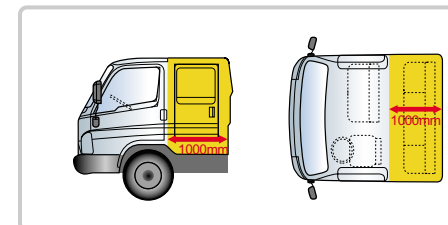

Double Your Profit with Double Cab

The extra seats in the rear cabin doubles the room for 3+4 people. Double cab essentially doubles the capacity for all kinds of cargoes, including people! With two-in-one, double your profit with Double Cab.

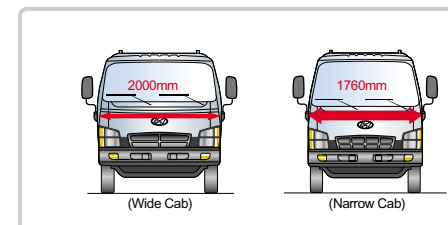

The Easy-to-handle and Agile Narrow Cab

For those hard-to-maneuver narrow streets, alleys and U-turns, the agile lean body can do the job anywhere and everywhere. With 240mm leaner width, the Narrow Cab drives like a car with multiple purpose and function. Narrow parking at streets and alleys is a welcome for this hard-working truck.

Reduced minimum turning radius

Shortened cab and deck width improve drivability on the narrow side street.

5.4m
(Narrow Cab)

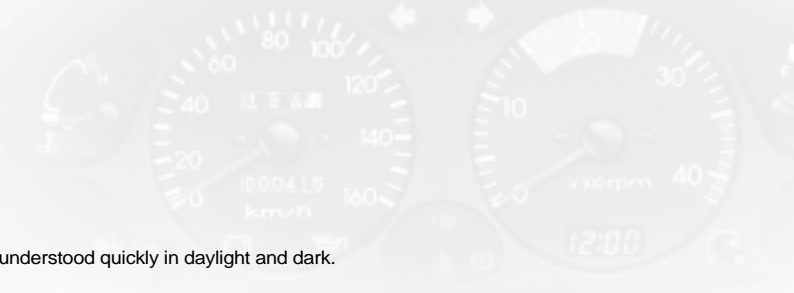

Designed by Drivers Not Engineers

Driving is a tough job: Days full of stops and starts and long hauls. That's why we asked drivers to help us design our new cabs. With their input, Hyundai has come up with new cab design that makes driving a lot easier. Every detail has been carefully designed for ergonomic efficiency. That means a minimum of effort and a maximum of driving pleasure.

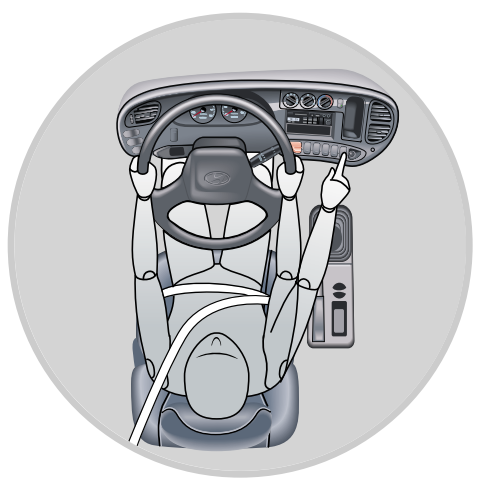
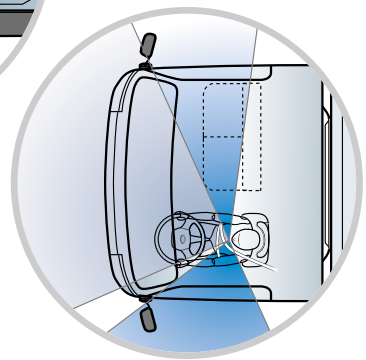

Excellent Field of View
With the new expanded windscreen and optimized seating position, drivers enjoy a maximum field of view. With better forward lines of sight drivers can confidently maneuver in tight spots. Frequently used controls have been placed within easy reach.

Air Control system



The cabin stays as warm or as cool as you like it thanks to the multiple vents and high output blower. Air conditioning is available as an option.



Easy-to-Use Rotary-type Switches



Instrument Panel
 Backlit gauges can be seen and understood quickly in daylight and dark.



Power Steering
 Steering requires just a minimum of effort for easy maneuvering.(option)



Tilt Steering Wheel
 Steering wheel can tilt at an angle that is just right for you for a safe and comfortable ride.



Telescopic Steering Column
 The telescopic steering column moves forward and backward to adjust perfectly to your sitting stance giving all the assurance of a confident driver.



Folding type Gear Shift
 The gear shift lever is fitted with a pleated rubberized boot, and folding type is option.



Parking Brake
 Pull-type parking brake is conveniently located in the center console.



Double Cab Parking Brakes
 The parking brake that safely parks the vehicle anywhere is smooth to operate and easy to handle.



Power Windows
 Power Window is an optional item for all models.



Wide Angle Doors
 Doors are hinged to provide an extra-wide door opening for easier entry and egress.



Overhead Console
 Optional for all DLX models. (Except Narrow Cab & STD Cab)



Console
 Center console includes storage bin, coin slot and cupholders. (Package opt)



Center Seat Back Console
 This is package optional for all DLX models. (Except Narrow Cab & Double Cab)



One Touch Ash Tray



Digital Clock
 Digital clock is standard on all models. (Except Standard trim)



Sunvisor
 Folding-type sunvisor is included for both driver and passenger.



Room Lamp
 Incandescent room lamp provides plenty of output for a bright interior.



Center Door Locks
 This safety and security feature is Optional for all DLX models.



Inside Rear View Mirror



Glove Box



H818 Audio

Premium audio system available for all DLX models as an optional item.



H700 Audio

H700 audio is standard on all models(Except standard trim)



Chassis & Frame

C H A S S I S & F R A M E

The front and rear axles ride on a rigid, leaf-type suspension and hydraulic shock absorbers for outstanding durability. The suspension is designed to handle maximum payloads without complaint.

Maximum Cargo Hauling Power

Computer-Aided Frame Design

Frame rails are designed with computer-aided design tools to provide the ultimate in strength and stability without incurring a substantial weight penalty.

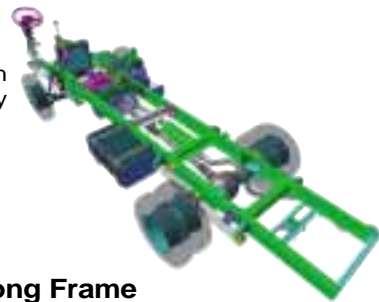

Extra-Strong Frame

Heat-treated steel frame is reinforced with crossmembers and new bolt-type fasteners which combine to improve resistance to frame twisting and flexing.

Suspension



Front Shock Absorber



Rear Shock Absorber



Leaf-Type Suspension



Booster 9+10 Inch tandem



Disc Brakes

Package option for HD65 model.



LSPV

Load sensing proportioning valve. (option)



Leaf-Type Suspension

Enjoy greater peace of mind knowing the HD65/72 series are fully equipped with advanced safety features. These include ABS, a load sensing proportioning valve to compensate for load distribution, front disc brakes, a tandem brake booster and door safety beams.

More Safety Features

ABS

Anti-Lock Brake System

Get better control of your truck with ABS which allows you to steer your way around trouble during emergency braking. This optional feature is part of the brake option package that includes power steering, front disc brakes with disc pad wear indicator and an auto adjuster for the rear drum brakes.

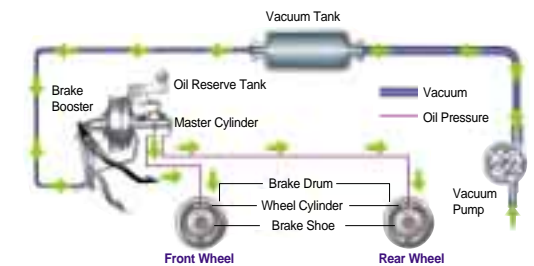

Maintenance & Power

MAINTENANCE & POWER



Tilting Cab

Servicing and routine checks are easier than ever thanks to the 50-degree tilting cab which provides quick and easy access to the engine compartment. (Except Double Cab)

It's So Easy

Hyundai makes it easy to perform routine visual inspections including checking important fluid levels, fuses and the replacement of burned out bulbs. That's because the new HD65/72 series is all about convenience.

More Choices, More Power

You expect more from a Hyundai and the HD65/72 series deliver with a new and improved family of diesel engines. Your choice includes the naturally aspirated 100ps D4AF, 120ps D4DC. If you want an intercooled turbo, Hyundai offers two: the 115ps D4AL or the top-end 3.9-liter D4DA which cranks out an impressive 155ps. Whatever you choose, you're assured of exceptional durability, power and low operating costs.

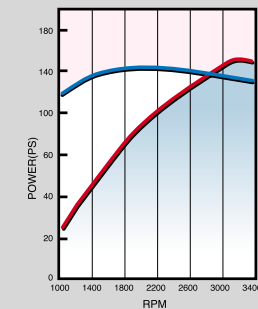

155 PS / 3200rpm

D4DA

Displacement : 3,907cc
Max Torque : 38kg.m/1,800rpm
Model : HD72

Turbo-charged Intercooled Power

By turbo-charging, air is compressed and unavoidably, it is heated thus degrading combustion efficiency. Intercooling greatly improves combustion efficiency by cooling down the turbo-charged air before intake into the cylinder.



D4AF 100 PS / 3,400rpm

Type : Naturally Aspirated
Displacement : 3,568cc
Max. Torque : 24kg.m/2,000rpm
Model : HD65



D4AL 115 PS / 3,400rpm

Type : Turbo-charged Intercooled
Displacement : 3,298cc
Max. Torque : 29kg.m/2,000rpm
Model : HD65/HD72



D4DC 120 PS / 3,200rpm

Type : Naturally Aspirated
Displacement : 3,907cc
Max. Torque : 30kg.m/1,800rpm
Model : HD65/HD72



D4DB 130 PS / 2,900rpm

Type : Turbo-charged Intercooled
Displacement : 3,907cc
Max. Torque : 37kg.m/1,600rpm
Model : HD72



D4DBD 120 PS / 3,000rpm

Type : Turbo-charged Intercooled
Displacement : 3,907cc
Max. Torque : 30kg.m/1,800rpm
Model : HD65



Radiator Reservoir Tank



Window Washer Reservoir Tank



Fuse box



Tool box



Auxiliary Engine Start Switch



Service Lamp Circuit

eck

D E C K

Line up

L I N E U P

A deck isn't just a deck, not when it's designed by Hyundai. We've made our decks to help make your job easier. For example, they're wider and longer than ever and include fold-down side and tail gates for extra cargo handling versatility.

Handy Features Help You Work



HD72 Long Wheel Base



HD65



HD72



Tail Gate Lock

Sturdy bolt mechanism is easy and quick to operate plus provides secure locking action.



Folding Side and Tail Gates

Side and tail gates drop down for easier cargo loading and unloading.



Chain Support

The cargo bed can be extended by dropping the tail gate which is supported by a hardened steel chain.



HD65 Standard Cab, Short Wheelbase



HD65 Narrow Cab, Long Wheelbase



HD65 Standard Cab, Long Wheelbase



HD72 Standard Cab, Short Wheelbase



HD65 Super Cab, Long Wheelbase



HD72 Standard Cab, Long Wheelbase



HD65 Double Cab, Long Wheelbase



HD72 Super Cab, Long Wheelbase



HD65 Narrow Cab, High Deck, Short Wheelbase

Colors



PT: Papyrus White



FQ: Coral Blue

ain Specifications

MAIN SPECIFICATIONS

| ITEM | | MODEL HD 6 5 | | | | | | | | | | | | | | | |
|---|-----------------------------|--|-------|-------|-------------|-------|-------|--------|-------|-------|--------|-------|-------|-------|-------|-------|-------|
| Drive System | | LHD, 4 × 2 | | | | | | | | | | | | | | | |
| Cab | Width | Narrow | | | | | | | Wide | | | | | | | | |
| | Length | Standard | | | | | | | Super | | Double | | | | | | |
| Wheel Base | | Short | | Long | | Short | | Long | | Long | | | | | | | |
| Application Engines | | D4AF | D4AL | D4AF | D4AL | D4AF | D4AL | D4DBD | D4AF | D4AL | D4DBD | D4DC | D4AF | D4AL | D4DC | D4AF | D4AL |
| Dimensions (mm) | | | | | | | | | | | | | | | | | |
| Wheel Base | | 2,550 | 3,375 | 2,750 | | | | 3,375 | | | | 3,570 | | 3,375 | | | |
| Overall | Length | 4,940 | 6,120 | 5,200 | | | | 6,120 | | | | 6,420 | | 6,120 | | | |
| | Width | 1,900 | | | | 2,030 | | | | | | | | | | | |
| | Height | 2,275 | | | | 2,285 | | | | | | | | | | | |
| Wheel Tread | Front | 1,475 | | | | 1,665 | | | | | | | | | | | |
| | Rear | 1,435 | | | | 1,495 | | | | | | | | | | | |
| Overhang(Body) | Front | 1,075 | | | | | | | | | | | | | | | |
| | Rear | 1,315 | 1,670 | 1,375 | | 1,670 | | 1,775 | | 1,670 | | | | | | | |
| Min.Ground Clearance | | 200 | | | | | | | | | | | | | | | |
| Weight (kg) | | | | | | | | | | | | | | | | | |
| Curb Vehicle Weight | | 2,545 | 2,585 | 2,690 | 2,700 | 2,625 | 2,670 | 2,645 | 2,745 | 2,815 | 2,790 | 2,815 | 2,815 | 2,845 | 2,845 | 2,840 | 2,880 |
| *Max. Gross Vehicle Weight | | 6,500 | | | | | | | | | | | | | | | |
| On the Front Axle Load | | 2,250 | | | | | | | | | | | | | | | |
| On the Rear Axle Load | | 4,250 | | | | | | | | | | | | | | | |
| *Max. GVW includes the front & rear axle loads based on the permissible tire load | | | | | | | | | | | | | | | | | |
| Calculated Performance | | | | | | | | | | | | | | | | | |
| Max. Speed (km/h) | | 107 | 109 | 107 | 109 | 106 | 109 | 103 | 106 | 109 | 103 | 110 | 106 | 109 | 110 | 106 | 109 |
| Max. Gradeability (tan) | | 0.401 | 0.416 | 0.395 | 0.416 | 0.395 | 0.416 | 0.414 | 0.383 | 0.416 | 0.414 | 0.346 | 0.377 | 0.416 | 0.346 | 0.356 | 0.416 |
| Min. Turning Radius (m) | | 5.4 | | 6.8 | | 5.0 | | 6.0 | | | | 6.5 | | 6.4 | | | |
| Specifications | | | | | | | | | | | | | | | | | |
| Engine | Model | D4AF | | | D4AL | | | D4DC | | | D4DBD | | | | | | |
| | Number of Cylinder | 4 in-line | | | | | | | | | | | | | | | |
| | Max. Power/Torque (ps/kg.m) | 100/24 | | | 115/29 | | | 120/30 | | | 120/30 | | | | | | |
| Battery | | MF 24V-90 AH | | | | | | | | | | | | | | | |
| Transmission | Model | M2S5 | | | M3S5/M035S5 | | | M3S5 | | | | | | | | | |
| | Type | 5 forward and 1 reverse | | | | | | | | | | | | | | | |
| Rear Axle ratio | | 6.666 | | | 5.714 | | | 6.166 | | | | | | | | | |
| Tire | | 7.00 × 16 -10PR | | | | | | | | | | | | | | | |
| Brake | Service Brake | Hydraulic with Vacuum servo assistant, dual circuit | | | | | | | | | | | | | | | |
| | Parking Brake | Internal expanding type on propellershaft at the rear of transmission assy | | | | | | | | | | | | | | | |
| | Exhaust Brake | Vacuum operated, butterfly valve type | | | | | | | | | | | | | | | |
| Suspension | | Semi-elliptic, laminated leaf springs with Shock absorber | | | | | | | | | | | | | | | |
| Fuel tank | | 80 liter(standard) or 100 liter(deluxe) | | | | | | | | | | | | | | | |

| ITEM | | MODEL HD 7 2 | | | | | | | | | | | |
|---|-----------------------------|--|-------|-------|--------|-------|-------|--------|-------|-------|--------|-------|------|
| Drive System | | LHD, 4 × 2 | | | | | | | | | | | |
| Cab | Width | Wide | | | | | | Wide | | | | | |
| | Length | Standard | | | | | | Super | | | | | |
| Wheel Base | | Short | | | Long | | | Long | | | | | |
| Application Engines | | D4DC | D4AL | D4DA | D4DB | D4DC | D4AL | D4DA | D4DB | D4DC | D4AL | D4DA | D4DB |
| Dimensions (mm) | | | | | | | | | | | | | |
| Wheel Base | | 2,750 | | | 3,735 | | | | | | | | |
| Overall | Length | 5,200 | | | 6,670 | | | | | | | | |
| | Width | 2,030 | | | 2,170 | | | | | | | | |
| | Height | 2,305 | | | | | | | | | | | |
| Wheel Tread | Front | 1,650 | | | | | | | | | | | |
| | Rear | 1,495 | | | | | | | | | | | |
| Overhang(Body) | Front | 1,075 | | | | | | | | | | | |
| | Rear | 1,375 | | | 1,860 | | | | | | | | |
| Min.Ground Clearance | | 235 | | | | | | | | | | | |
| Weight (kg) | | | | | | | | | | | | | |
| Curb Vehicle Weight | | 2,695 | 2,825 | 2,945 | 2,985 | 3,040 | | | 3,015 | | | 3,055 | |
| *Max. Gross Vehicle Weight | | 7,200 | | | | | | | | | | | |
| On the Front Axle Load | | 2,400 | | | | | | | | | | | |
| On the Rear Axle Load | | 4,800 | | | | | | | | | | | |
| *Max. GVW includes the front & rear axle loads based on the permissible tire load | | | | | | | | | | | | | |
| Calculated Performance | | | | | | | | | | | | | |
| Max. Speed (km/h) | | 108 | 105 | 130 | 106 | 108 | 105 | 130 | 106 | 108 | 105 | 130 | 106 |
| Max. Gradeability (tan) | | 0.317 | 0.353 | 0.417 | 0.38 | 0.317 | 0.353 | 0.401 | 0.38 | 0.317 | 0.353 | 0.4 | 0.38 |
| Min. Turning Radius (m) | | 5.0 | | | | | | 7.3 | | | | | |
| Specifications | | | | | | | | | | | | | |
| Engine | Model | D4DC | | | D4AL | | | D4DA | | | D4DB | | |
| | Number of Cylinder | 4 in-line | | | | | | | | | | | |
| | Max. Power/Torque (ps/kg.m) | 120/30 | | | 115/29 | | | 155/38 | | | 130/37 | | |
| Battery | | MF 24V-90 AH | | | | | | | | | | | |
| Transmission | Model | M3S5 | | | | | | M035S5 | | | | | |
| | Type | 5 forward and 1 reverse | | | | | | | | | | | |
| Rear Axle ratio | | 6.666 | | | 6.666 | | | 5.428 | | | | | |
| Tire | | 7.50 × 16 -12PR | | | | | | | | | | | |
| Brake | Service Brake | Hydraulic with Vacuum servo assistant, dual circuit | | | | | | | | | | | |
| | Parking Brake | Internal expanding type on propellershaft at the rear of transmission assy | | | | | | | | | | | |
| | Exhaust Brake | Vacuum operated, butterfly valve type | | | | | | | | | | | |
| Suspension | | Semi-elliptic, laminated leaf springs with Shock absorber | | | | | | | | | | | |
| Fuel tank | | 80 liter(standard) or 100 liter(deluxe) | | | | | | | | | | | |

Annotations

- 1) This vehicle specifications may differ per country and allow for production tolerance.
- 2) Curb vehicle weight includes weight of oil, fuel, coolant and spare tire carrier & bracket, spare tire but exclude standard tool set.
- 3) Hyundai Motor Company reserve the right to make change in specifications, equipments and design, or to discontinue models or options without notice at any time.

HD65

Standard Cab | Short Wheelbase

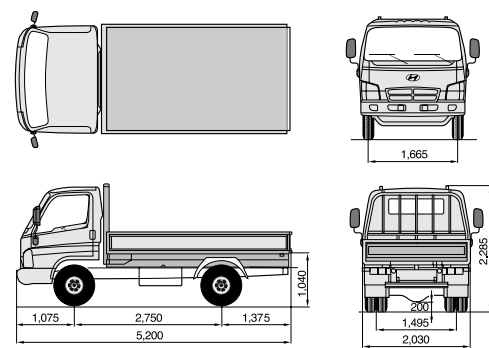

Standard Cab | Long Wheelbase

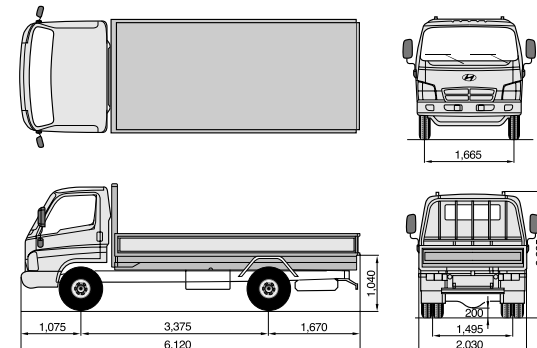

Narrow Cab | Short Wheelbase

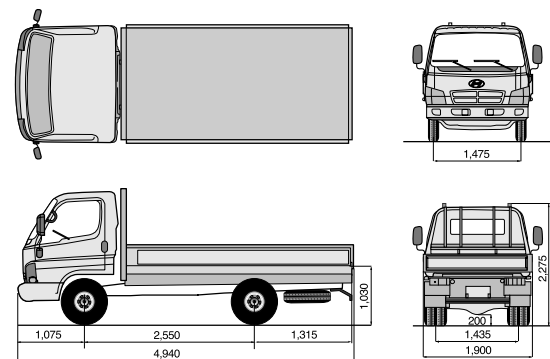

Narrow Cab | Long Wheelbase

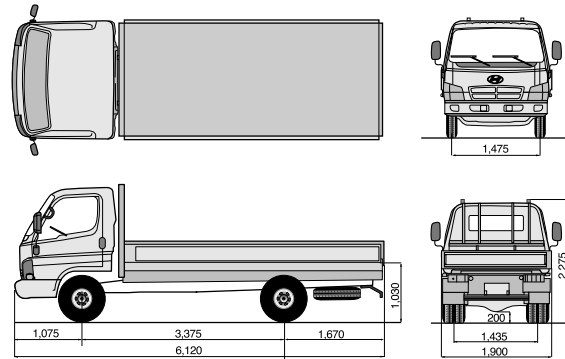

Super Cab | Long Wheelbase

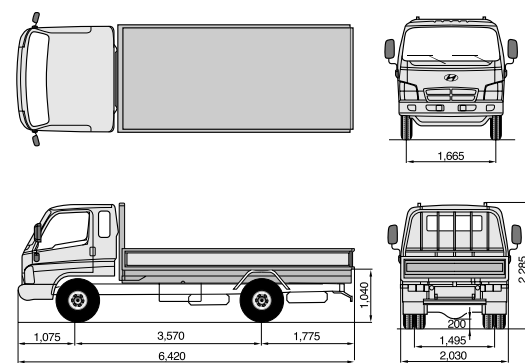

Double Cab | Long Wheelbase

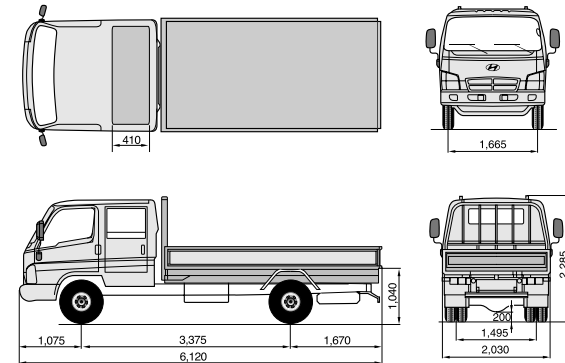

HD72

Standard Cab | Short Wheelbase

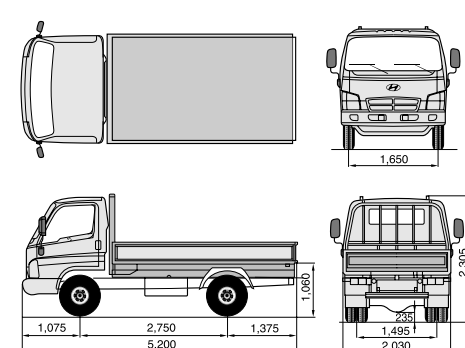

Standard Cab | Long Wheelbase

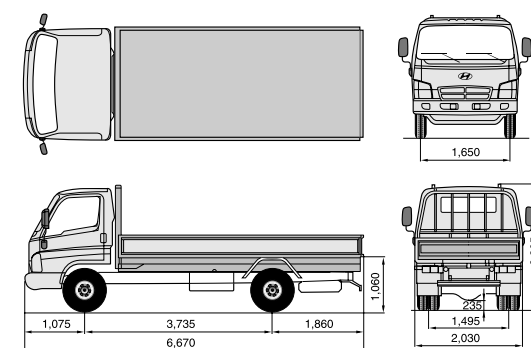

Super Cap | Long Wheelbase

